

3 PC Direct Mount Ball Valve for Actuation

VB3B-DMBT

FULL BORE
 BLOW OUT PROOF STEM
 ISO 5211 ACTUATOR MOUNTING FLANGE
 DIRECT MOUNT
 1000 PSI (69 BAR) W.O.G.
 INVESTMENT CAST BODY & CAP
 TESTING TO API 598
 THREADED, SOCKET WELD & BUTT WELD ENDS
 SEAT/SEAL: 15% REINFORCED GLASSFIBER PTFE
 TEMP RANGE -20 – 200 DEG C



NO	PART NAME	MATERIALS	
1	BODY	CF8M	WCB
2	CAP	CF8M	WCB
3	BALL	CF8M	CF8M
4	BALL SEAT	15% GLASS FILLED PTFE	
5	GASKET	15% GLASS FILLED PTFE	
6	STEM	AISI 316	
7	THRUST WASHER	15% GLASS FILLED PTFE	
8	PACKING	15% GLASS FILLED PTFE	
9	HIGH WASHER	S/S 304	
10	BELLEVILLE WASHER	S/S 304	
11	C - TYPE RETAINING RING	S/S 304	
12	O-RING	S/S 304	
13	BOLT	S/S 304	
14	SPRING WASHER	S/S 304	
15	HEX NUT	S/S 304	

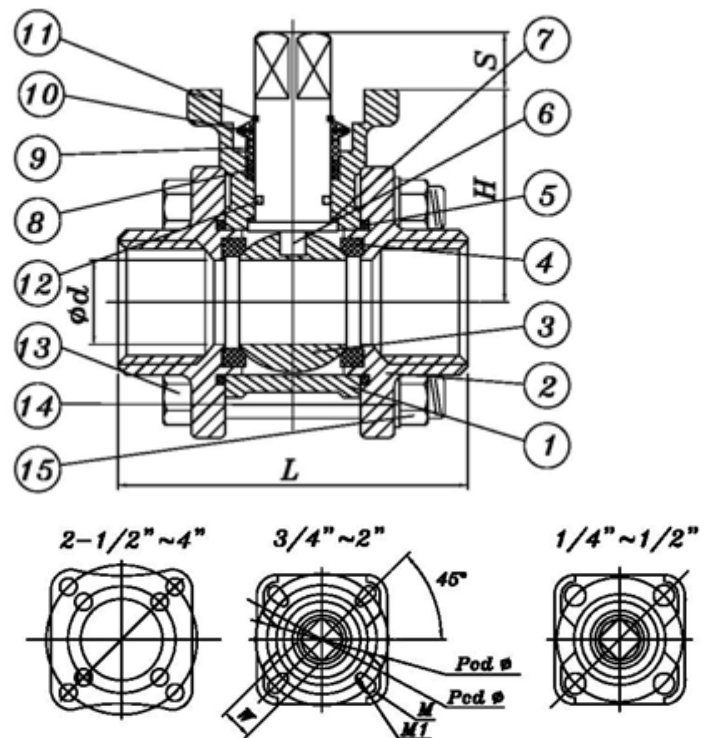

DIMENSIONS:

SIZE	d	L	H	S	ISO 5211					Cv FACTOR	TORQUE N-m *
					PCD	ø	W	M	M1		
1/4"	11.6	58	36	9.6	F03	ø 36	9	ø6.0	-	6.6	4
3/8"	12.8	58	36	9.6	F03	ø 36	9	ø6.0	-	7.9	4
1/2"	16	62	38	9.6	F03	ø 36	9	ø6.0	-	11.2	5
3/4"	20	77	41.7	11.6	F03/F04	ø 36/ø 42	9	ø7.0	ø6.0	21	9
					F04/F05	ø 42/ø 50					
1"	25	83	44.4	11.6	F04/F05	ø 42/ø 50	11	ø7.0	ø6.0	34	11
1 1/4"	32	94	52.8	11.2	F05/F07	ø 50/ ø 70	11	ø9.0	ø7.0	57	16
1 1/2"	38	107	58.5	11.2	F05/F07	ø 50/ ø 70	14	ø9.0	ø7.0	80	22
2"	50	120	66	11.2	F05/F07	ø 50/ ø 70	14	ø9.0	ø7.0	148	33
2 1/2"	65	156	101.5	18.5	F07/F10	ø 70/ ø 102	17	ø11	ø9.0	265	40
3"	80	182	112.5	18.5	F07/F10	ø 70/ ø 102	17	ø11	ø9.0	415	66
4"	100	213.6	127	18.5	F07/F10	ø 70/ ø 102	17	ø11	ø9.0	780	95

*Torque figures are for break torque and do not include any safety factor. Figures calculated at atmospheric pressure and temperature.

Energy Valves is a division of Energy Engineered Products (Pty) Ltd.
 30 Monte Carlo Crescent Kyalami Park, Midrand, South Africa

Tel: +27 11 466 1926 Fax: +27 11 466 1692 Email: sales@energyproducts.co.za Web: www.energyproducts.co.za