

3 PC Lever Operated Ball Valve

VB3B – 3 Piece Ball Valve

FULL BORE

BLOW OUT PROOF STEM

LOCKING DEVISE

1000 PSI (69 BAR) W.O.G.

INVESTMENT CAST BODY & CAP

TESTING TO API 598

THREADED, SOCKET WELD & BUTT WELD ENDS

SEAT/SEAL: 15% REINFORCED GLASSFIBER PTFE

TEMP RANGE -20 – 200 DEG C



ENERGY VALVES

NO	PART NAME	MATERIALS	
1	BODY	CF8M	WCB
2	CAP	CF8M	WCB
3	BALL	CF8M	CF8M
4	BALL SEAT	15% GLASS FILLED PTFE	
5	GASKET	15% GLASS FILLED PTFE	
6	STEM	AISI 304	
7	THRUST WASHER	PTFE	
8	PACKING	PTFE	
9	GLAND NUT	S/S 304	
10	HANDLE	S/S 304	
11	STEM WASHER	S/S 304	
12	STEM NUT	S/S 304	
13	PLASTIC COVER	PLASTIC	
14	BOLT	S/S 304	
15	SPRING WASHER	S/S 304	
16	HEX NUT	S/S 304	

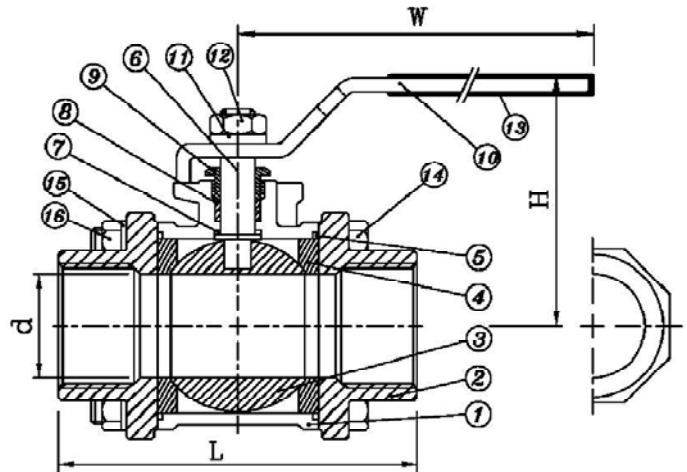

DIMENSIONS:

SIZE	d	L	H	W	Cv FACTOR	TORQUE N-m *	Kgs
¼"	11.6	52	48	100	6.6	4.5	0.29
3/8"	11.6	52	48	100	7.9	4.5	0.29
½"	15	63.4	52	100	10	5	0.39
¾"	20	71	61	127	25	7.4	0.61
1"	25	80.6	65	127	35	11.4	0.86
1 ¼"	32	94	79	154	46	17.8	1.37
1 ½"	38	104	83	154	80	22	2.04
2"	50	126.4	97	192	110	26	3.74
2 ½"	65	160	135	244	310	48.5	6.44
3"	80	179.5	144	244	360	155.9	10.20
4"	100	220	157	280	820	272	24.1

*Torque figures are for break torque and do not include any safety factor.

Energy Valves is a division of Energy Engineered Products (Pty) Ltd.
30 Monte Carlo Crescent Kyalami Park, Midrand, South Africa

Tel: +27 11 466 1926 Fax: +27 11 466 1692 Email: sales@energyproducts.co.za Web: www.energyproducts.co.za